

Transportation

# Height control valves

Aftermarket  
Replacement  
Catalog

Control  
Control  
every move



Barksdale  
CONTROL PRODUCTS  
CRANE

**Barksdale**  
CONTROL PRODUCTS

**CRANE** Barksdale, Inc./Barksdale GmbH  
A Subsidiary of Crane Co.

# Barksdale

## The Shear-Seal® advantage



In 1992 the industry expectation for commercial vehicle air suspension height control valves was limited. Available HCV designs were based on seals that wore rapidly, requiring frequent replacement. As the seals failed, height control performance deteriorated and air consumption increased. Valve replacement and downtime costs were rising with trucking demand.



Barksdale Controls identified the need for a solution and developed a series of height control valves based on its patented **Shear-Seal®** technology. Today Barksdale supplies Original Equipment valves to some of the most prestigious commercial vehicle manufacturers in the world. Our success continues to be driven by our ability to combine high value customized solutions with best in class customer support.

Barksdale invented the **Shear-Seal®** principle, and since 1949 has used the technology in our valves with great success in demanding applications such as steel and paper mills, oil exploration and processing, and defense. Utilization of Shear-Seal® technology in air suspension height control valve applications yielded breakthrough improvements in durability and performance. The **Shear-Seal®** principle is based on the sliding of two precisely machined metal sealing surfaces across each other, creating a zero-leak\* seal. Contaminants cannot score the seals because flow is through the **Shear-Seal®** rather than across the sealing surface. Precision engineering and manufacturing combine for unmatched performance and reliability.



Bringing zero-leakage, long life **Shear-Seal®** technology to commercial vehicle ride control applications changed the industry and made Barksdale Controls the leader in suspension control technology.

\*Less than 4 cc per minute.



• Specifications are subject to modification at any time



# Height control valves

## Height control valves

ORIGINAL EQUIPMENT QUALITY AND PRECISION FOR  
AFTERMARKET CAB AND CHASSIS SUSPENSION APPLICATIONS

### General Product Information

- ▶ Direct replacement height control valves for all makes of cab air suspension and chassis applications.
- ▶ Bolt in installation. No drilling is required.
- ▶ Manufactured by the largest supplier of air suspension height control valves to the US truck industry.
- ▶ Designed and produced by an ISO 9001: 2000 certified facility to OE specifications.



### Features and Benefits

- ▶ **Shear-Seal® Design** wears in, not out. Hardened valve components resist wear from air system contaminants.
- ▶ **Dual Air Bag Ports** for ease of installation.
- ▶ **Zinc Plated, Anodized Aluminum, and Engineered Plastics** combine for superior corrosion resistance.
- ▶ **Proportional Response** controls air flow for precise ride control.
- ▶ **100% Tested at Factory** to ensure reliable performance.
- ▶ **Integral Dump Valve** with air pilot activation saves space and simplifies installation.

### Warranty

**Barksdale Height Control Valves are backed by a one-year unlimited mileage warranty.**

Barksdale Part	Replaces Part Number
KD2360	International 2506169C91 Hadley HAD500NS
KD2356	WABCO S464 002 443-0 Midland KN 27000
KD2358	Hadley H00500RS
KD2357	Haldex/Neway 90054007
KD2355	WABCO S464 007 004-0
KD2359	WABCO 464 008 115-0
KD2373	Delco/King of the Road 12C-1 (KOR 5549705) & 12-6-2 (KOR 5549706)
KD2374	Haldex PR 90554950 & 90554945
KD2375	Hadley H00450CE

# Height control valves

**KD2360 Replaces: International 2506169C91  
Hadley HAD500NS**



- ▶ Chassis Air Ride Applications
- ▶ Integral Dump Feature
- ▶ 1/4" NPT Ports
- ▶ Bolt-in installation
- ▶ No drilling required

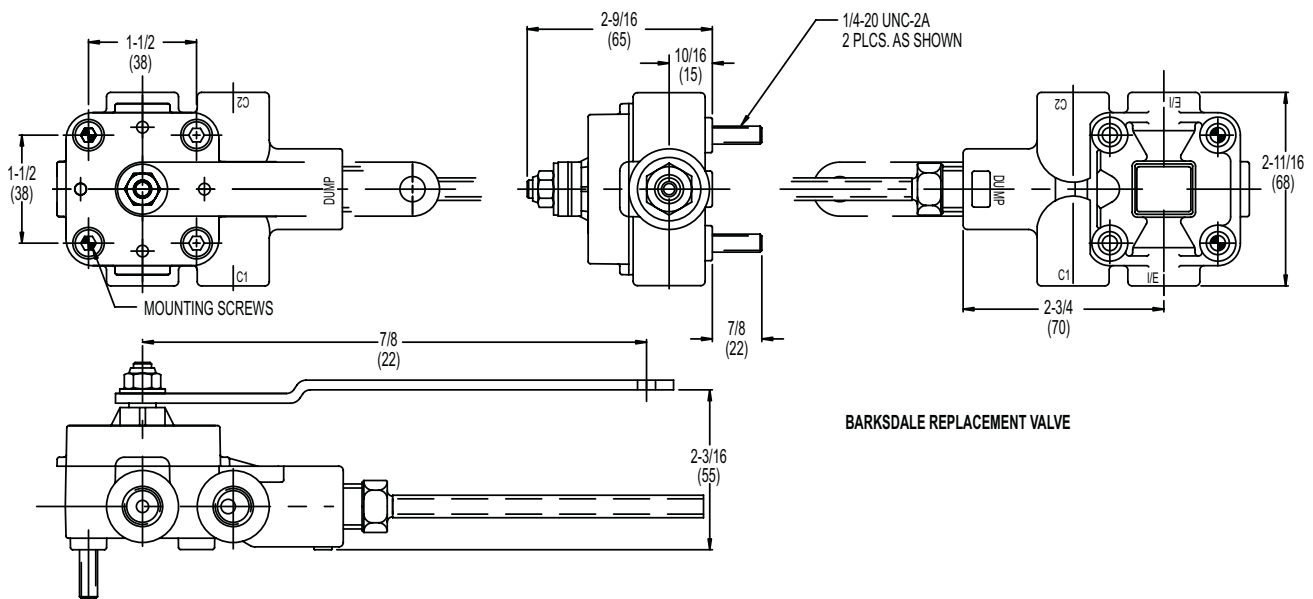

• Specifications are subject to modification at any time



# Height control valves

**KD2356 Replaces: WABCO S464 002 443-0  
Midland KN 27000**



- ▶ Chassis Air Ride Applications
- ▶ 1/4" NPT Ports
- ▶ Bolt-in installation
- ▶ No drilling required

**WABCO OR MIDLAND VALVE**

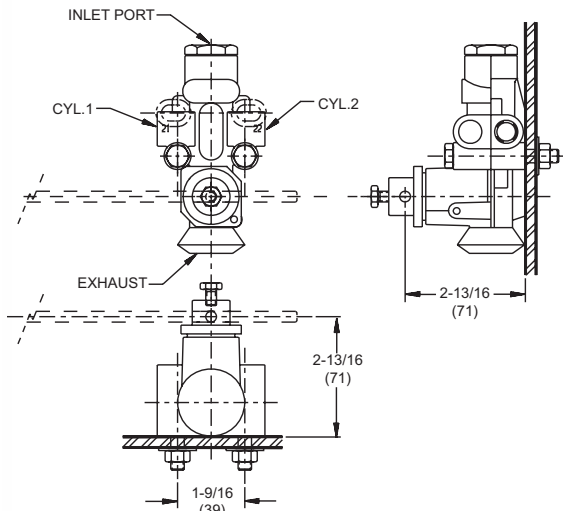

**BARKSDALE REPLACEMENT VALVE**

**BRACKET INTERCHANGEABLE WITH WABCO/MIDLAND VALVES**

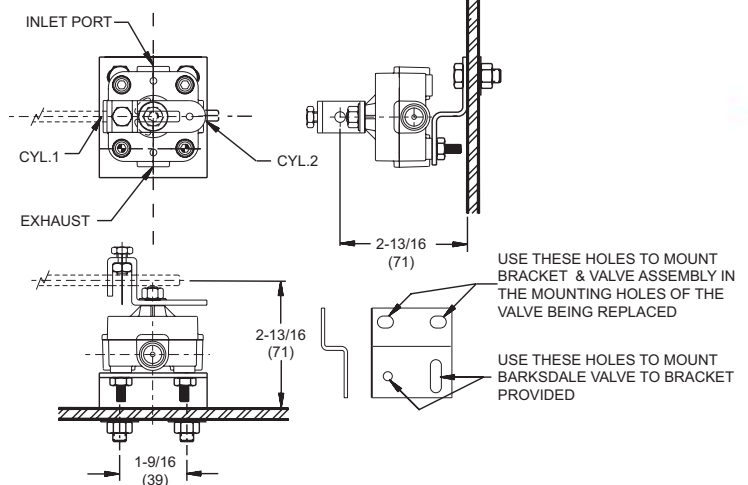

VIEW FROM THE REAR OF THE TRUCK LOOKING FORWARD

• Specifications are subject to modification at any time

# Height control valves

**KD2358 Replaces: Hadley H00500RS**



- ▶ Chassis Air Ride Applications
- ▶ Integral Dump Feature
- ▶ 1/4" NPT Ports
- ▶ Compression Fittings Included
- ▶ Bolt-in installation
- ▶ No drilling required

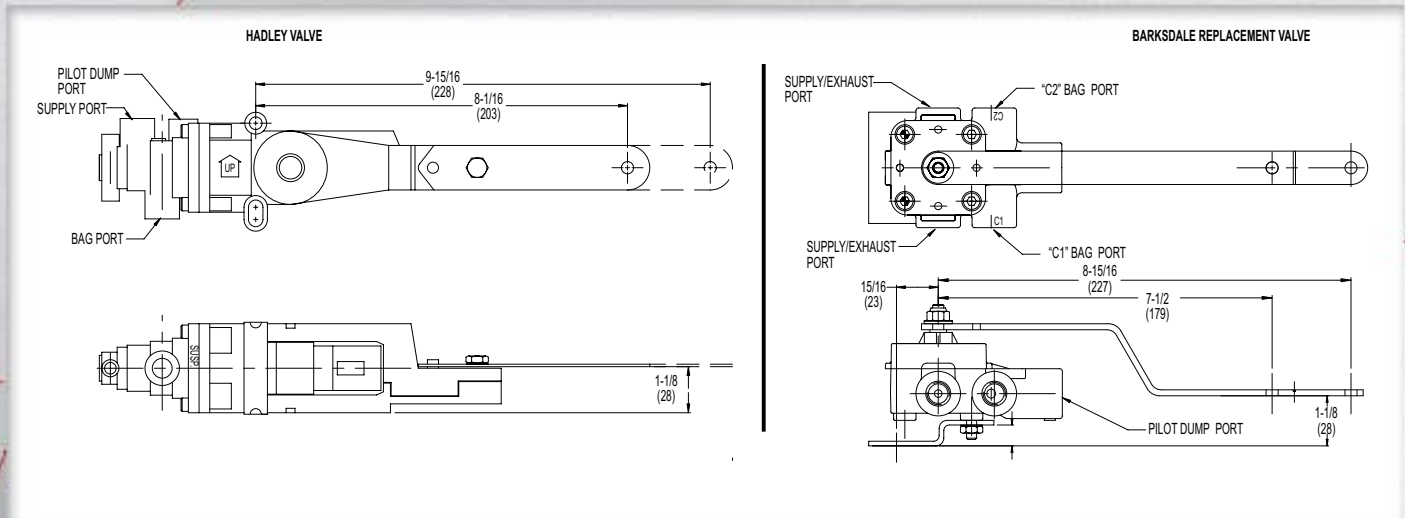

• Specifications are subject to modification at any time

# Height control valves

**KD2357 Replaces: Haldex/Neway 90054007**



- ▶ Chassis Air Ride Applications
- ▶ 1/4" NPT Ports
- ▶ Bolt-in installation
- ▶ No drilling required

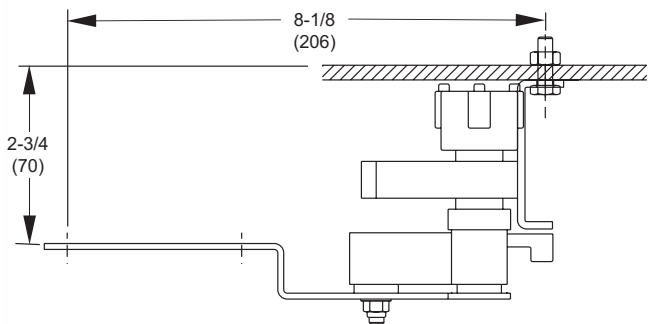

**NEWAY VALVE**

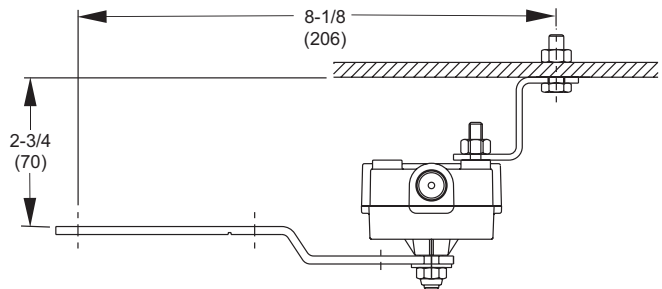

**BARKSDALE REPLACEMENT VALVE**

• Specifications are subject to modification at any time



# Height control valves

**KD2355 Replaces: WABCO S464 007 004-0**

- ▶ Cab Air Ride Applications
- ▶ Integral 1/4" Push to Connect Fittings
- ▶ Bolt-in installation
- ▶ No drilling required

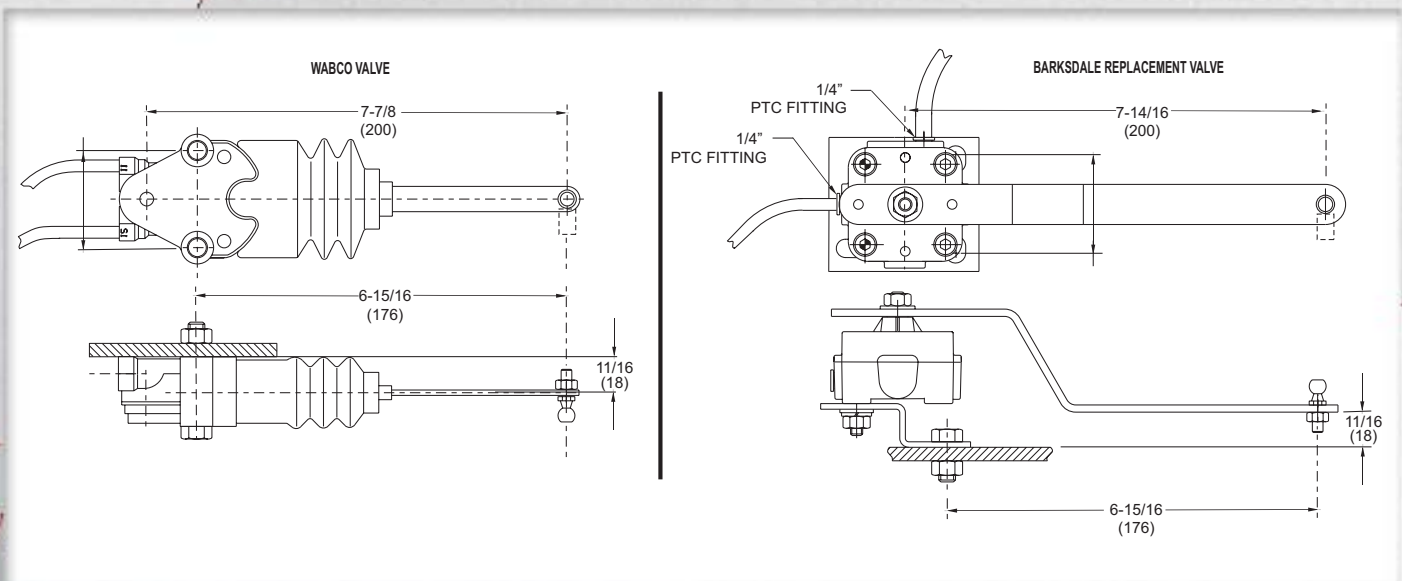

• Specifications are subject to modification at any time



# Height control valves

## Height control valves

**KD2359 Replaces: WABCO 464 008 115-0**



- ▶ Chassis Air Ride Applications
- ▶ Integral Dump Feature
- ▶ 1/4" NPT Ports
- ▶ Bolt-in installation
- ▶ No drilling required

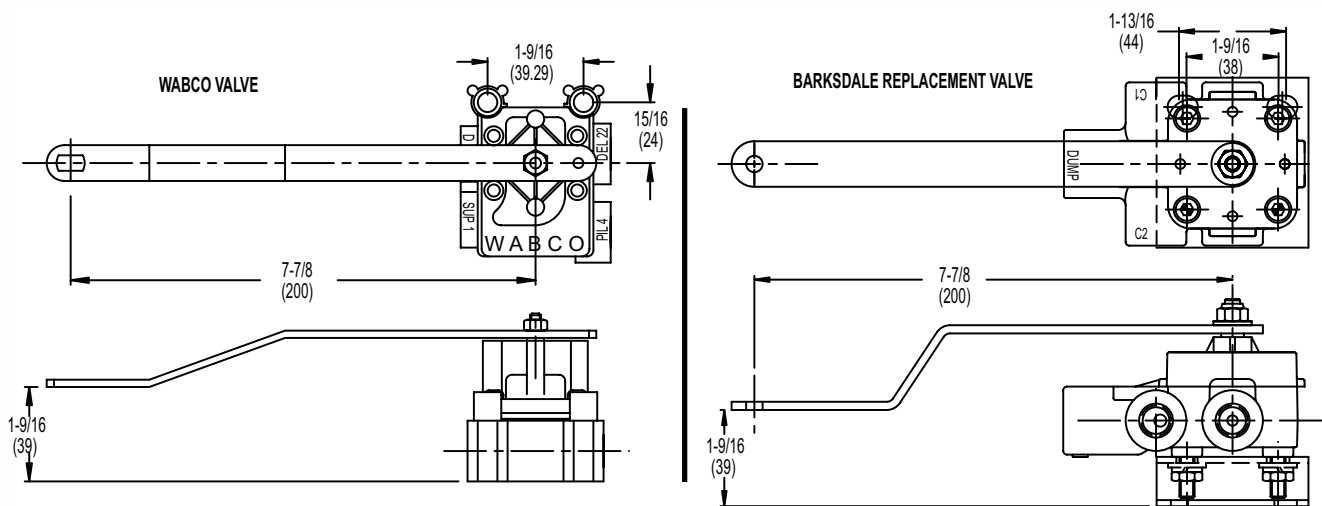

• Specifications are subject to modification at any time

# Height control valves

**KD2373 Replaces: Delco/King of the Road  
12C-1 (KOR 5549705) &  
12-6-2 (KOR 5549706)**

- ▶ Chassis Air Ride Applications
- ▶ 1/4" NPT Ports
- ▶ 1/4" Compression Fittings
- ▶ Bolt-in installation
- ▶ No drilling required

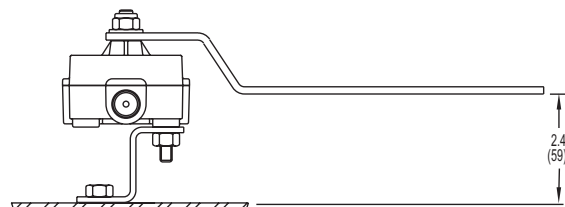
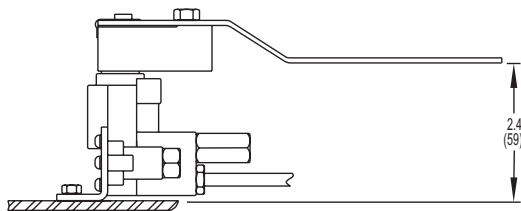
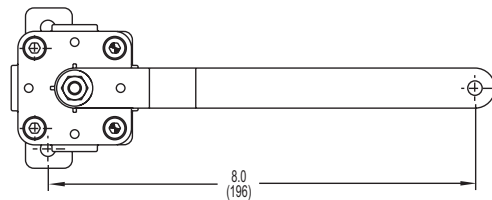
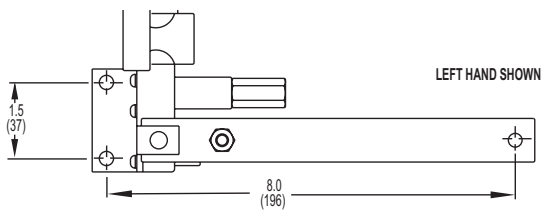

• Specifications are subject to modification at any time



# Height control valves

## Height control valves

**KD2374 Replaces: Haldex PR 90554950 & 90554945**



- ▶ Chassis Air Ride Applications
- ▶ Integral Dump Feature (normally closed)
- ▶ 1/4" NPT Ports
- ▶ Bolt-in installation
- ▶ No drilling required

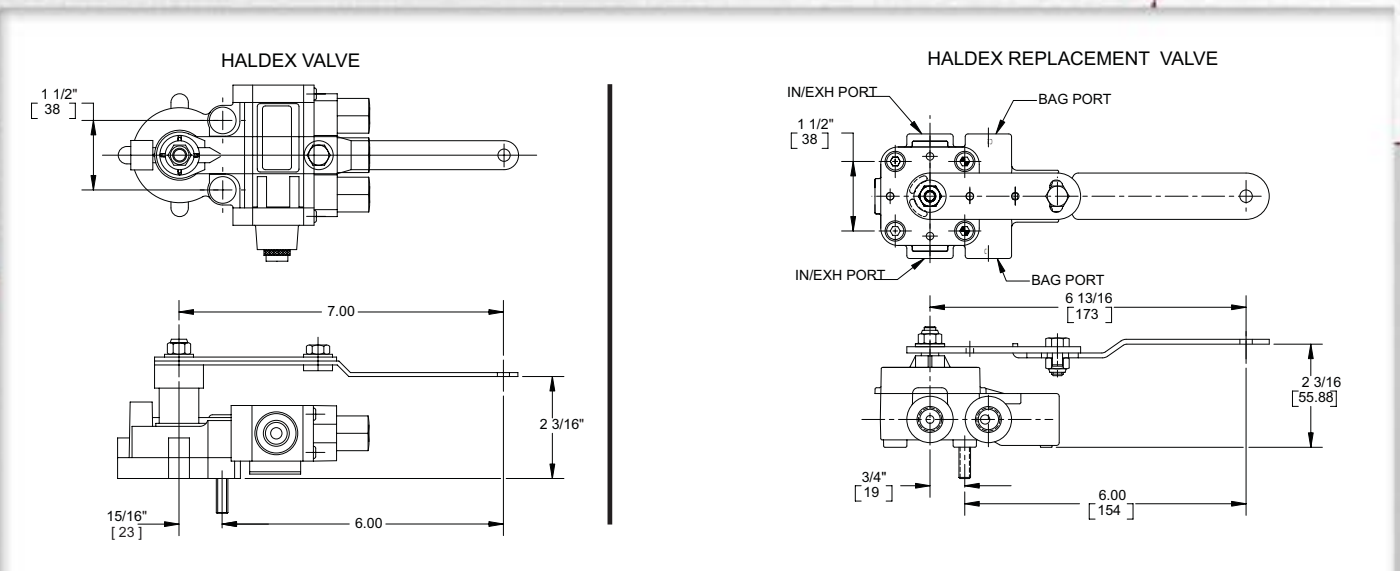

• Specifications are subject to modification at any time

# Height control valves

**KD2375 Replaces: Hadley H00450CE**



- ▶ Cab & Chassis Air Ride Applications
- ▶ Requires re-use of the Hadley® HCV arm
- ▶ 1/4" NPT Ports
- ▶ Bolt-in installation
- ▶ No drilling required

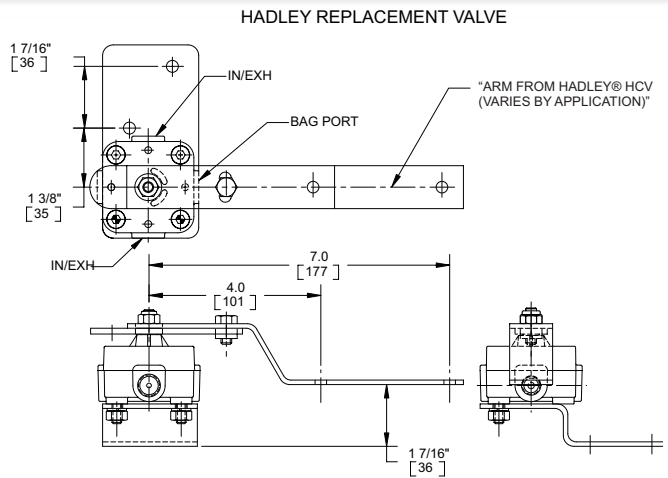
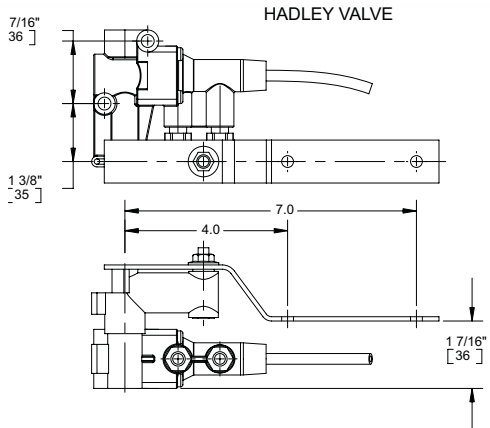

• Specifications are subject to modification at any time



# Universal Linkage Assembly

## Adjustable Linkage

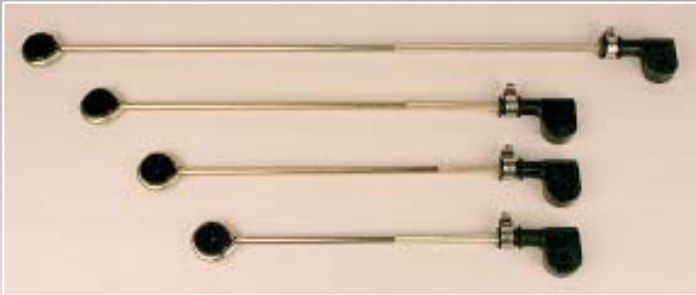

Universal Linkage Kit	Dimension "A" Adjustment Range (inch/mm)	Description
320138	6.9 - 9.6 / 175 - 244	Adjustable Linkage
320139	9.8 - 11.5 / 250 - 292	Adjustable Linkage
320140	10.9 - 13.6 / 277 - 345	Adjustable Linkage
320141	12.8 - 19.0 / 325 - 482	Adjustable Linkage

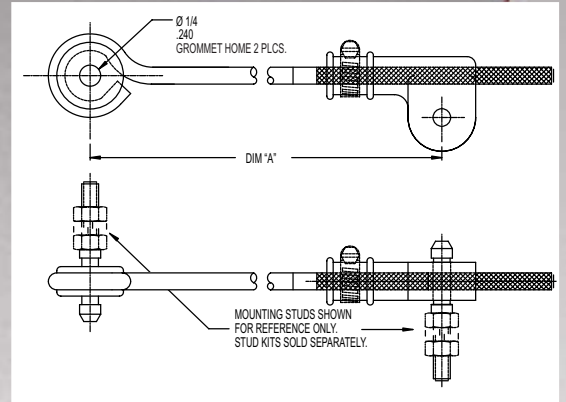

- ▶ Zinc-Plated Steel Rod
- ▶ Elastomer Ends

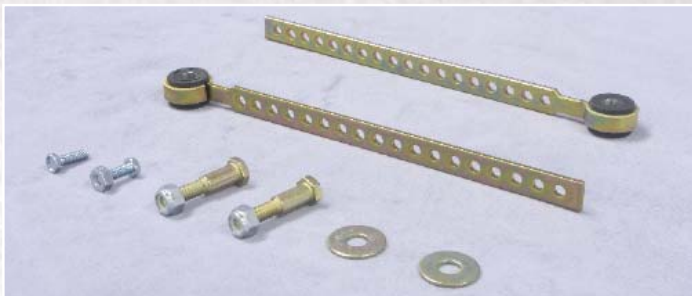

- ▶ Adjusts from 8 3/4" (220 mm) to 14 1/2" (370 mm)
- ▶ 1/4" Diameter mounting bolts

## Linkage Hardware



Linkage Hardware 5/16-18  
KD2370



Linkage Hardware 1/4-20  
KD2371



Linkage Hardware(metric) 8 mm  
KD2372

Universal Hardware Kit	Replaces	Description
KD2370	Best Fit	Mounting Hardware / 5/16-18 Thread
KD2371	Best Fit	Mounting Hardware / 1/4-20 Thread
KD2372	Best Fit	Mounting Hardware / 8 mm Coarse Thread

• Specifications are subject to modification at any time

# Installation Instructions

## General Installation Instructions

### Valve Removal

Shut-off air flow to Height Control Valve.

Disconnect the Linkage from control arm.

Disconnect air lines to the Height Control Valve.

Caution: Air lines are under pressure and air may blow debris.

- ▶ For Push-To-Connect Fittings, depress the manual push button then pull the tube out.
  - ▶ For Compression Fittings, loosen compression nut and pull tube from compression seat.
- Remove valve from frame.

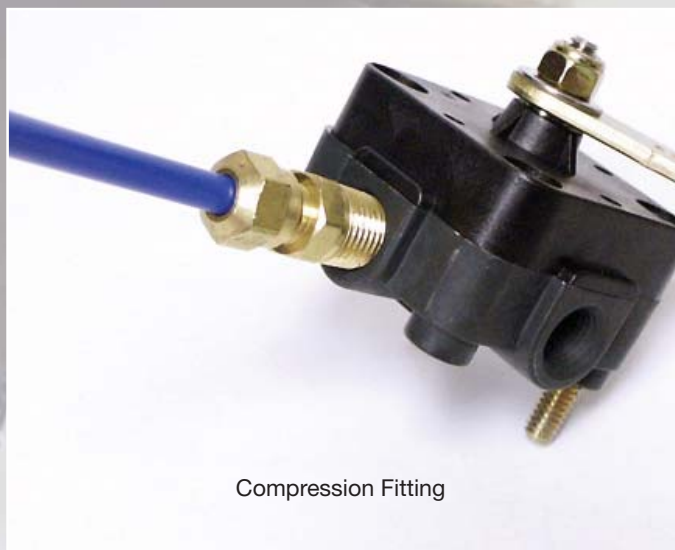

### Typical Barksdale Height Control Valve

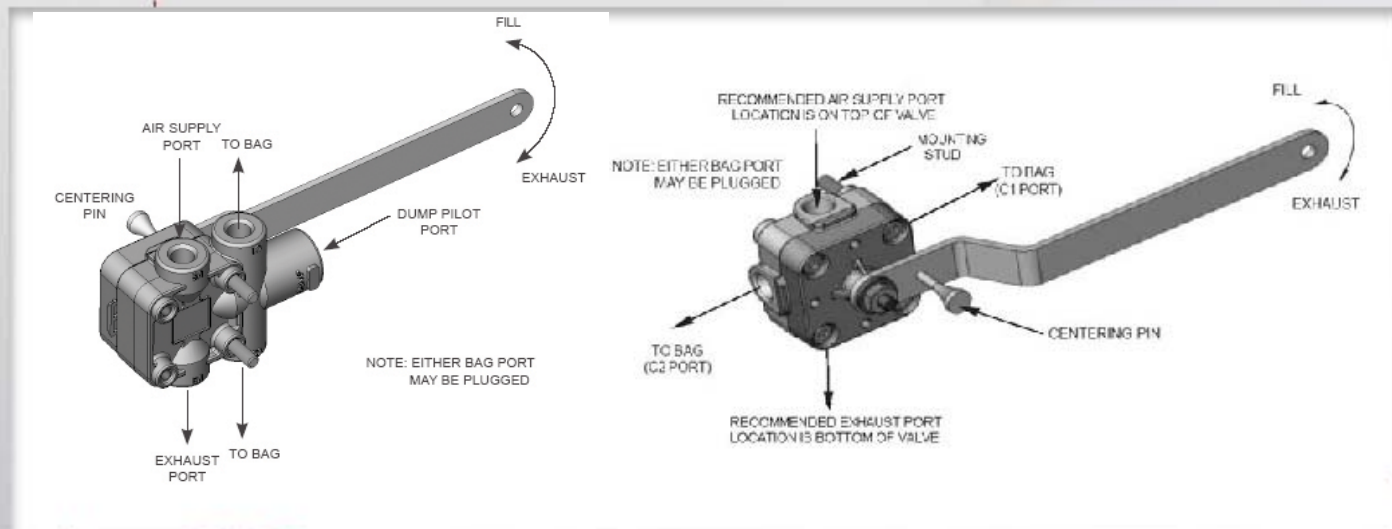



# Installation guide

## General Installation Instructions

1. Apply thread sealant to either the new fittings provided or existing fittings removed from previous valve.
2. Install fittings according to air line size into Height Control Valve.
3. Attach bracket to the mounting screws of the Height Control Valve.

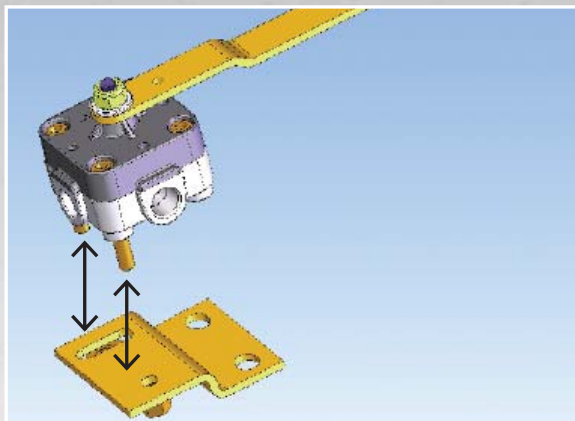

4. Mount Height Control Valve, with attached bracket, to the frame.
5. Hand tighten nuts.
6. Connect air lines to fittings of Height Control Valve. Inlet port is identified as port orientated up.
  - ▶ For Push-To-Connect Fittings:
    - ❑ Cut tubing using tube cutter to achieve square cut of tube.
    - ❑ Pull on tubing to verify gripping action. (Tubing should not slip out)
  - ▶ For Compression Fittings
    - ❑ Remove compression nut and compression ring from fitting.
    - ❑ Slide compression nut followed by compression ring over tubing.
    - ❑ Push tubing into compression seat and tighten compression nut. (The compression ring will compress against tubing as nut is tightened.)
7. Adjust ride height by rotating the handle to the Fill/Exhaust position, allowing air to enter/exit the air bags. If installing Height Control Valve with Integral Dump proceed as following: Note: 3-way pilot valve is required.
  - ▶ Connect air line from pilot valve to Dump Port of Height Control Valve.
  - ▶ Apply 65 psi of air pressure to the Dump Port of the Height Control Valve activating the piston, allowing air to be “dumped “ from the air bags.
8. When the desired ride height, as specified by the vehicle manufacturer, is achieved rotate the handle to the neutral position. Install Centering Pin through handle hole and into the valve body.
9. Adjust Height Control Valve with mounting bracket to achieve final ride height according to the Truck Manufacturers recommended height.
10. Tighten all nuts and torque to 45 in/lb.
11. Remove Centering Pin.

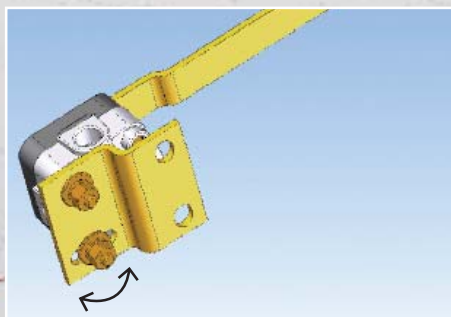



**Barksdale Inc.**  
3211 Fruitland Ave.  
Los Angeles, CA 90058-0843  
U.S.A.  
Phone: (866) 832-6278  
Fax: (323) 589-3463  
Email: [transportation@barksdale.com](mailto:transportation@barksdale.com)  
[www.barksdale.com](http://www.barksdale.com)

**Barksdale GmbH**  
Dorn-Assenheimer Strasse 27  
61203 Reichelsheim, Germany  
Phone: (49) 6035-949-0 (main office)  
(49) 6035-949-204 (sales)  
Fax: (49) 6035-949-111/-113  
Email: [info@barksdale.de](mailto:info@barksdale.de)  
[www.barksdale.de](http://www.barksdale.de)

**Barksdale**  
CONTROL PRODUCTS  
CRANE Barksdale, Inc./Barksdale GmbH  
A Subsidiary of Crane Co.